

XFAC Zone Controller

Versatile and Easy to Install Wireless Zone Control

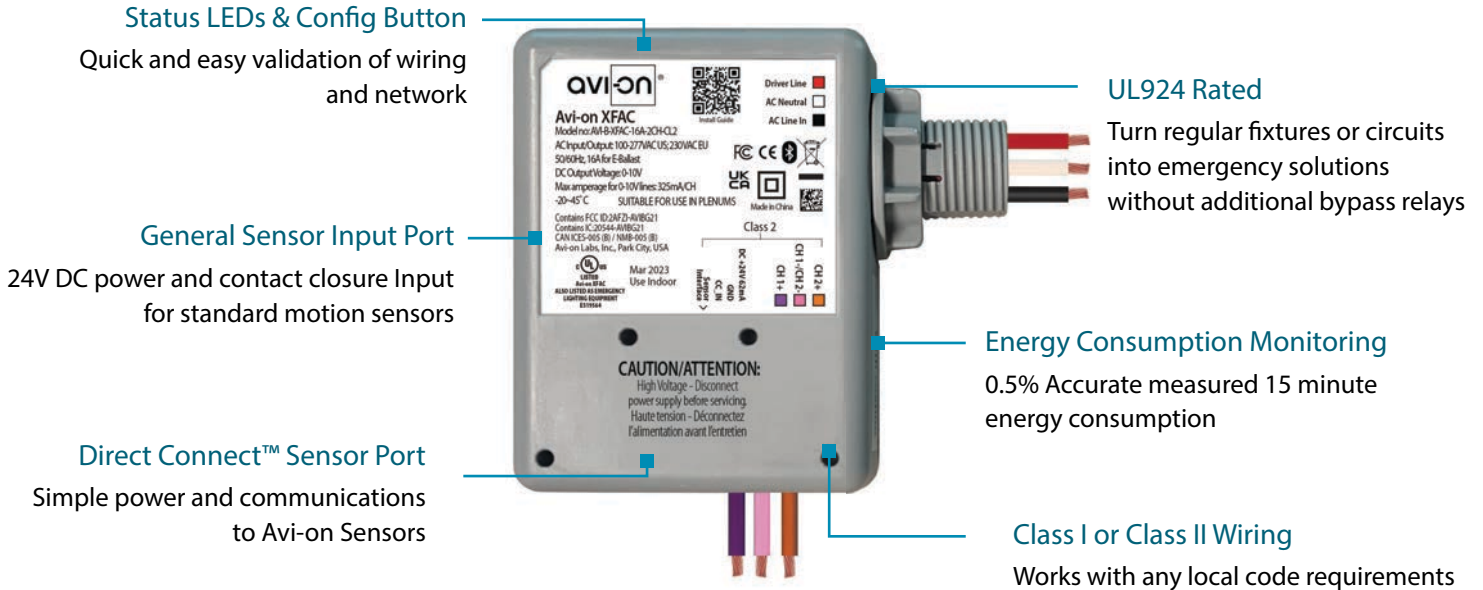

PRODUCT OVERVIEW

Description

The XFAC is a highly capable wireless zone controller with loads of additional features. 110-277V, 16A Lighting rated relay, high capacity 0-10V dimming, and multiple sensor integration options make this a single component solution for an entire zone based control solution.

Flexible Installation

The XFAC is available in Class I or Class II wiring options. The XFAC is fully networked and integrated with the Avi-on ecosystem and is interoperable with all other Avi-on sensors, wall stations, and fixture controllers.

Sensor Ready

The XFAC is a sensor integration powerhouse with 2 different sensor inputs: Plug any Avi-on Direct Connect sensor for easy sensor integration, or use the general purpose sensor input with 24VDC power and contact input with third party sensors.

Energy Monitoring

The XFAC includes true measured energy consumption readings every 15 minutes (>0.5% accuracy). Use the XFAC to comply with top tier utility rebate programs and corporate energy management initiatives.

UL 924 Rated

The XFAC is rated as an emergency lighting control appliance. Use to control zones or individual fixtures without adding bypass relays. Trigger emergency status for fixtures across an entire building for applications using Uninterruptible Power Supplies (UPS) or based on triggers from Building Control Systems (BCS). Order the -EM version for emergency mode to be pre configured, or enable/disable emergency mode for any XFAC unit with Avi-on Pro.

Color Changing Capable

Available with 2 0-10V outputs to control color changing (CCT) lights

Project		Location/ Type	
---------	--	-------------------	--

ORDERING INFORMATION

Part Number	Supply Voltage	Channels	Configuration	Relay
AVI-B-XFAC-16A-1CH-CL1	100 - 277 VAC	Single	Class 1	16 Amp*
AVI-B-XFAC-16A-1CH-CL2	100 - 277 VAC	Single	Class 2	16 Amp*
AVI-B-XFAC-16A-2CH-CL2	100 - 277 VAC	Dual (CCT)	Class 2	16 Amp*
AVI-B-XFAC-16A-1CH-CL1-EM	100 - 277 VAC	UL 924 Enabled	Class 1	16 Amp*
AVI-XFAC-16A-1CH-CL2-EM	100 - 277 VAC	UL 924 Enabled	Class 2	16 Amp*
AVI-B-XFAC-16A-ENERGY	XFAC Without Control Capability - Energy Monitoring of Circuit Only			

*Connect 16A of LED Lighting Devices (no further de-rating needed)

To order please contact Avi-on sales at **(877) AVION-US**, (877) 284-6687 or prosales@avi-on.com for information on becoming an Avi-on partner and order details.

SPECIFICATIONS

Specifications	Min	Max	Unit
Supply Voltage US	100	277	VAC
Supply Voltage EU	220	240	VAC
Operating Current Consumption (100 VAC / 277 VAC)	20 / 14	81 / 46	mA
Operating Current Consumption (230 VAC)	14	46	mA
Output Voltage 0-10V_OUT	0.02	10.35	V
Storage Temperature	-40/-40	+185/+85	°F/°C
Ambient Operating Temperature	-4/-20	+113/+45	°F/°C
Relay Current (Electronic Ballast/LED Driver)	-	16	A
Amperage for 0-10V lines		325	mA/CH

High Voltage Connections

Signal Name	Wire Color	Description
AC VOLTAGE (LINE)	BLACK (AC LINE)	AC 100-277VAC, #14
NEUTRAL	WHITE	AC neutral/common, #18
LINE DRIVER	RED	Relay controlled AC output (switched line), #14

Low Voltage Connections (Isolated)

Signal Name	Wire Color	Description
0-10V_OUT[1]+	PURPLE	User controllable 0-10VDC (dimming), #18
0-10V_OUT[2]+	ORANGE	User controllable 0-10VDC (CCT), #18
0-10V_OUT[1&2]-	PINK	Common dimming negative, #18
DC + 24V 62mA*	Terminal	24 Volt DC output, #16-#24, Max 62mA
GND -	Terminal	Common ground, #16-#24
CC_IN	Terminal	24 Volt Sensor input, #16-#24

*Aux port current available with no AVI-DC-MW installed

Case Dimensions (Excluding Wires)

Part	Length	Width	Height
All	3.58" (91mm)	3.58" (91mm)	1.57" (40mm)

Protection/Immunity (non-regulatory):

AC-input/user input and output connections:
ESD Level-4 immunity per IEC/EN 61000-4-2

Level	Contact Discharge	Air Discharge
4	±8 kV	±12 kV

AC-input: EFT and BUSRTS immunity IEC/EN 61000-4-4, Class3 or better (=<2kV)

AC-input: SURGE immunity IEC/EN 61000-4-5, Class3 or better (=<2kV)

EU Regulatory

Over-voltage: Category III
Signal Indicator: LED ON Represents LOAD OFF
Glow-wire temperatures: 650°C /850°C
PCB Coating Type: Type 2

Certifications

Regulatory	Description
USA	FCC: FCC ID: 2AFZI-AVIBG21 FCC Part 15, Subpart B (Class B) FCC Part 15.247
EU	BS EN IEC 55015:2019+A11:2020 / EN IEC 55015:2019+A11:2020 BS EN 61547:2009 / EN 61547:2009 BS EN IEC 61000-3-2:2019+A1:2021 / EN IEC 61000-3-2:2019+A1:2021 BS EN 61000-3-3:2013+A1:2019 / EN 61000-3-3:2013+A1:2019 ETSI EN 301 489-1 V2.2.3 (2019-11) ETSI EN 301 489-17 V3.2.4 (2020-09) BS EN IEC 61058-1:2018 / EN IEC 61058-1:2018 BS EN 61058-1-2:2016 / EN 61058-1-2:2016 BS EN 62479:2010 / BS EN 62479:2010 BS EN 50663:2017 / EN 50663:2017 ETSI EN 300 328 V2.2.2 (2019-11)
Canada	IC: 20544-AVIBG21 ICES-005, Issue 5, Dec. 2018 RSS-GEN Issue 5, Feb. 2021 Amendment 2 RSS-247 Issue 2, Feb. 2017
BQB	DID: D059595 Qualified Design ID (QDID): 185220
UL	UL 60730-1 ED. 5 UL 924 ED. 10 UL 2043 ED. 4

DIMENSIONS & WIRING DIAGRAMS

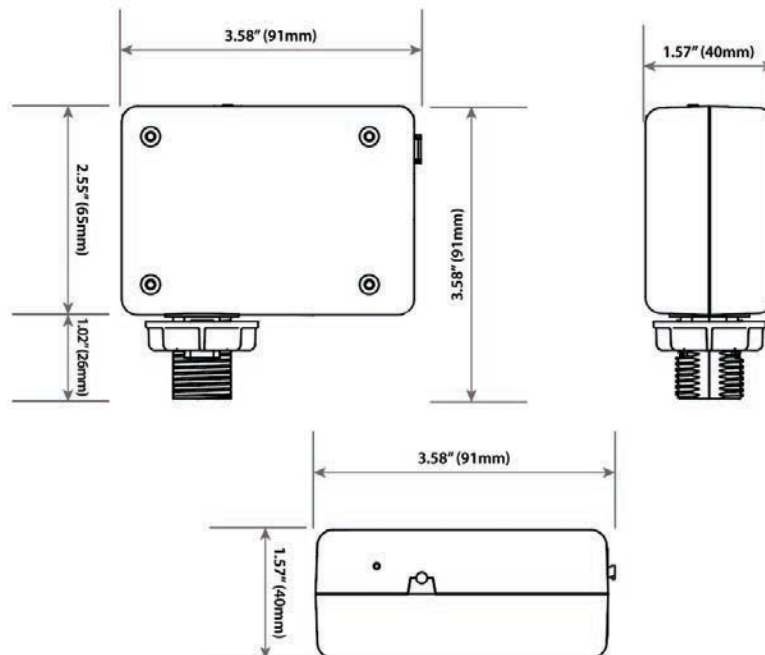

Figure 1. Dimensions

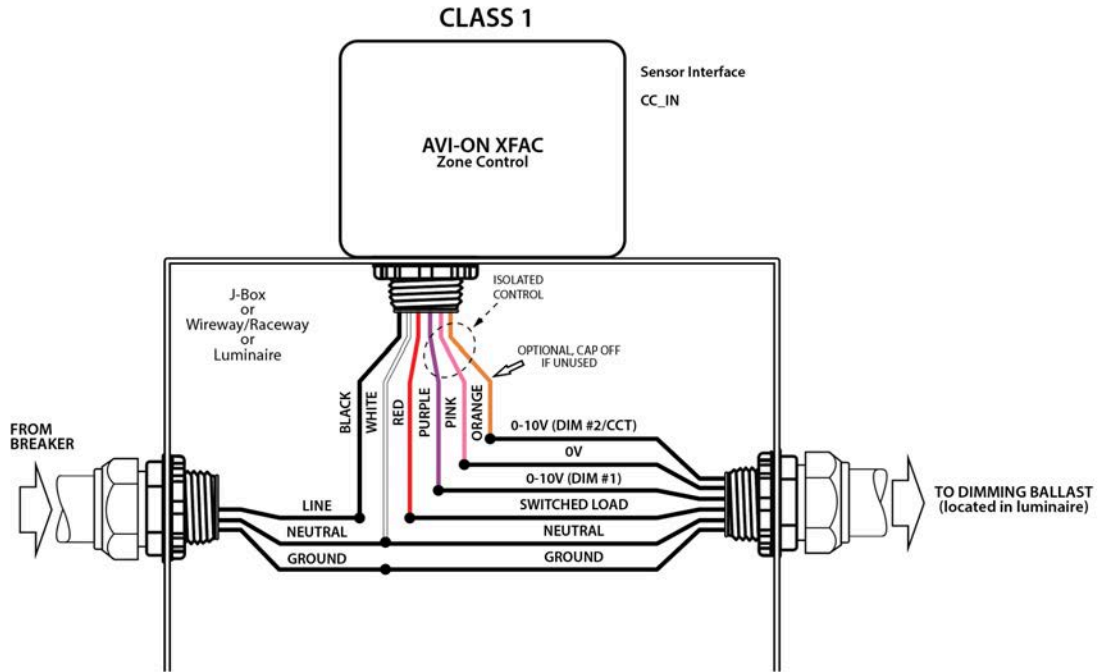

Figure 2. Class I Wiring Diagram

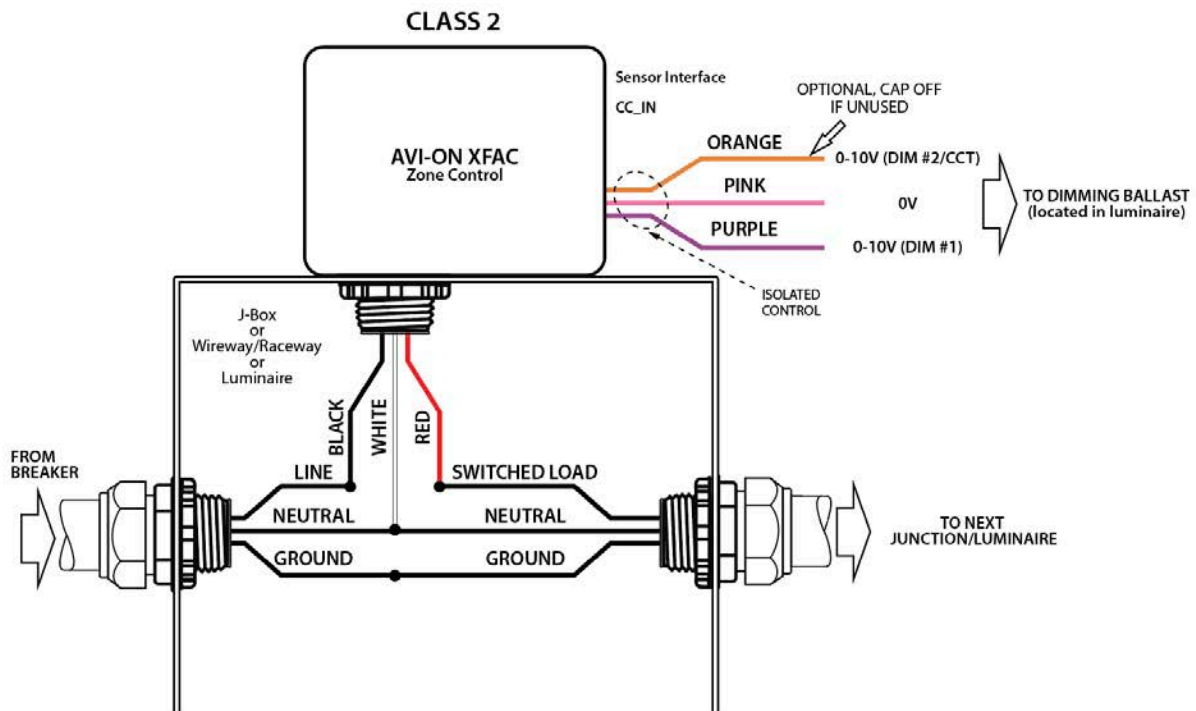

Figure 3. Class II Wiring Diagram

ALL PRODUCT, PRODUCT SPECIFICATIONS AND DATA ARE SUBJECT TO CHANGE WITHOUT NOTICE TO IMPROVE RELIABILITY, FUNCTION OR DESIGN OR OTHERWISE. The information contained herein is believed to be reliable. Avi-on makes no warranty, representation or guarantee regarding the information contained herein, the suitability of the products for any particular purpose, or the continuing production of any product. Avi-on assumes no responsibility or liability whatsoever for the use of the information contained herein. The information contained herein, or any use of such information does not grant, explicitly or implicitly, to any party any patent rights, licenses, or any other intellectual property rights, whether with regard to such information itself or anything described by such information.

