

Internal Fixture Adapter (IFAC)

Fixture-Integrated Adapter Works With Any 1-10V Fixture.

Terminal Blocks
Faster, easier and lower cost installation eliminating connectors

Direct Connect™ Sensor Port
Simple and cost-effective addition of Avi-on sensors

Status LEDs & Config Button
Quick and easy validation of wiring and network

Built In Energy Monitoring
Measured Energy Consumption

Works with Any Fixture
Internal 5A relay plus 0-10V Dimming, 110V-277V



PRODUCT

Description

The IFAC series fixture adapter mounts inside lighting fixtures proving addressability for each luminaire. All fixture adapters are part of the Avi-on® Bluetooth® with Mesh product ecosystem supported by the Avi-on mobile app, commissioning tools and cloud IoT Services.

Operation

The IFAC supports 110V-277VAC. Plug any 1-10V dimmable fixture into the IFAC. The IFAC includes a 5A relay to switch the power off to the fixture. Includes dual 0-10V outputs for color changing and built in 15 minute energy monitoring (0.5% accurate).

Direct Connect™ Ready

Just plug any Avi-on Direct Connect Sensor into the sensor port for easy sensor integration. Sensor is powered directly from the IFAC.

Applications

The IFAC is Avi-on's most versatile individual fixture controller. It works with any 1-10V dimming driver.

The IFAC is an easy solution for almost any indoor commercial lighting project including offices, manufacturing, warehouses, schools, gymnasiums, common areas, UV-C lighting control, and outdoor area lights, floods, canopies in garage, open parking, site, and athletic facilities.

Just plug an Avi-on Direct Connect PIR or Microwave motion and daylight sensor into the IFAC for easy lighting control solutions, whether zone based or Luminaire Level Lighting Controls (LLLC).

Use the IFAC whenever individual fixture energy consumption monitoring is needed to qualify for energy rebates or support corporate energy management initiatives.

Finally, the 2-channel 0-10V model is ideal for projects with tunable white requirements.

ORDERING INFORMATION

Part Number	Supply Voltage	Channels	Relay
AVI-B-IFAC-5A	110 - 277 VAC	Single	5 Amp
AVI-B-IFAC-5A-CCT	110 - 277 VAC, CCT activation	Dual	5 Amp
AVI-B-IFAC-5A-WC	110 - 277 VAC, Warm/Cool activation	Dual	5 Amp
AVI-B-IFAC-5A-OA	110 - 277 VAC, Outdoor Antenna	Single	5 Amp
AVI-B-IFAC-5A-CCT-OA	110 - 277 VAC, CCT activation, Outdoor Antenna	Dual	5 Amp
AVI-B-IFAC-5A-WC-OA	110 - 277 VAC, Warm/Cool activation, Outdoor Antenna	Dual	5 Amp

To order please contact Avi-on sales at **(877) AVION-US**, (877) 284-6687 or prosales@avi-on.com for information on becoming an Avi-on partner and order details.

Project		Location/Type	
----------------	--	----------------------	--

SPECIFICATIONS

Electrical

Specifications	Min	Max	Unit
Supply Voltage US	110	277	VAC
Supply Voltage EU	220	240	VAC
Operating Current Consumption (110/277 VAC)	19/13	124/72	mA
OperatingCurrent Consumption(230VAC)	13	72	mA
OutputVoltage 0-10V_OUT	0.0	10.0	V
OutputCurrent0-10V_OUT	0.0	25.0	mA
Storage Temperature	-40	+85	°C
Amblent Operating Temperature	-30	+80	°C
Relay Current [General Use (GP) / Tungsten / Electric/Magnetic Ballast /LED Driver]	-	5.0	A

High Voltage Terminal Connections (Isolated)

Signal Name	Terminal Color	Description
DRIVER LINE	GREEN / ORANGE	AC 110-277VAC US; 230VAC EU
DRIVER NEUTRAL	GREEN / ORANGE	AC Neutral/Common
AC NEUTRAL	GREEN / ORANGE	AC Neutral/Common
AC LINE IN	GREEN / ORANGE	Relay Switched AC (output)
GROUND	YELLOW w/GREEN STRIPE	Earth Ground

Low Voltage Terminal Connections (Isolated)

Signal Name	Terminal Color	Description
CH1+ (DIM)	GRAY	Dimming 0-10VDC.
CH1- (DIM)	GRAY	Dimming Negative
CH2+ (CCT)	GRAY	CCT 0-10VDC
CH2- (CCT)	GRAY	CCT Negative

Certifications

Regulatory	Description
USA	FCC: FCC ID: 2AFZI-AVIBG21 FCC Part 15, Subpart B (Class B) FCC Part 15.247
EU	BS EN IEC 55015:2019+A11:2020 / EN IEC 55015:2019+A11:2020 BS EN 61547:2009 / EN 61547:2009 BS EN IEC 61000-3-2:2019+A1:2021 / EN IEC 61000-3-2:2019+A1:2021 BS EN 61000-3-3:2013+A2:2021 / EN 61000-3-3:2013+A2:2021 ETSI EN 301 489-1 V2.2.3 (2019-11) ETSI EN 301 489-17 V3.2.4 (2020-09) BS EN IEC 61058-1:2018 / EN IEC 61058-1:2018 BS EN 61058-1-2:2016 / EN 61058-1-2:2016 BS EN 62479:2010 / EN 62479:2010 BS EN 50663:2017 / EN 50663:2017 ETSI EN 300 328 V2.2.2 (2019-11)

Regulatory	Description
Canada	IC: IC ID: 20544-AVIBG21 ICES-005, Issue 5, Dec. 2018 RSS-GEN Issue 5, Feb. 2021 Amendment 2 RSS-247 Issue 2, Feb. 2017
BQB	DID: D059595 Qualified Design ID (QDID): 185220
UL	UL 60730-1 ED.5 UL 2043 ED.4

SPECIFICATIONS

Case Dimensions (Excluding Wires)

Part	Length	Width	Height
All	6.02 in (153mm)	1.38 in (35mm)	0.98 in (25mm)

AC-input: SURGE immunity IEC/EN 61000-4-5, Class3 or better ($= < 2kV$)

Protection/Immunity (non-regulatory):

Level	Contact Discharge	Air Discharge
4	$\pm 8 kV$	$\pm 12 kV$

AC-input: EFT and BUSRTS immunity IEC/EN 61000-4-4, Class3 or better ($= < 2kV$)

AC-input/user input and output connections: ESD Level-4 immunity per IEC/EN 61000-4-2

WIRING DIAGRAMS

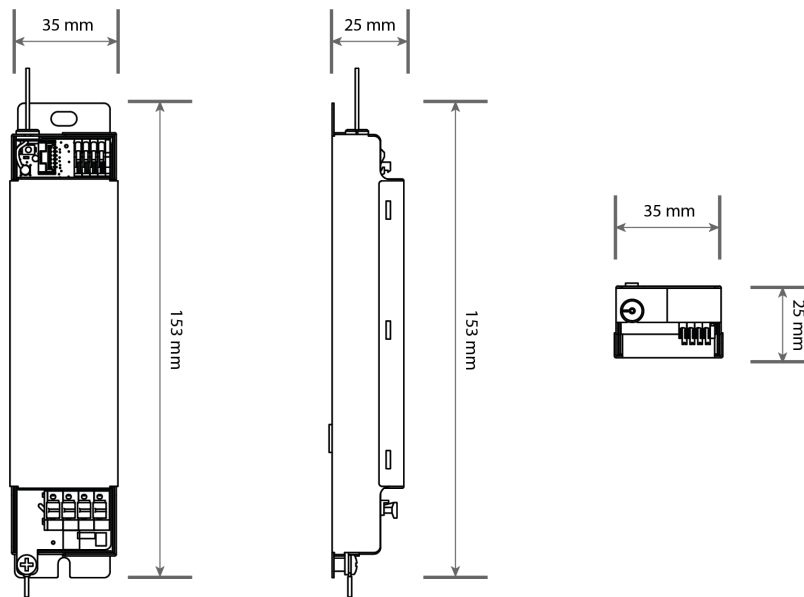

Figure 1. IFAC Dimensions

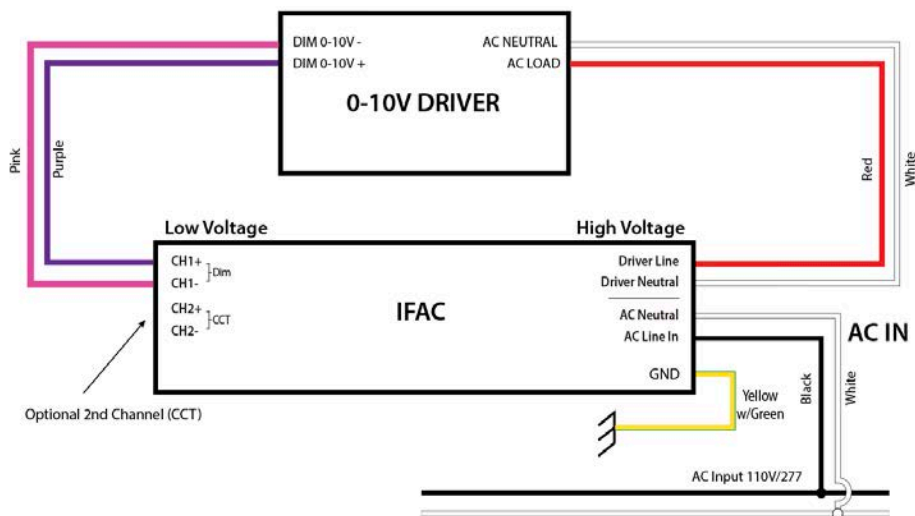

Figure 2. Wiring Diagram (1CH)

WIRING DIAGRAMS

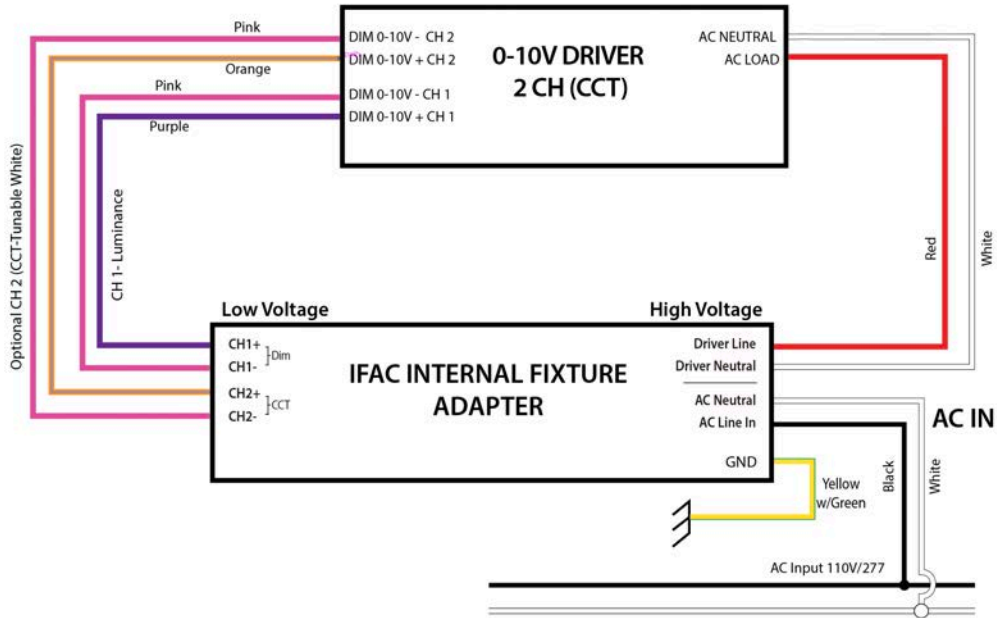

Figure 3. Wiring Diagram (2CH CCT)

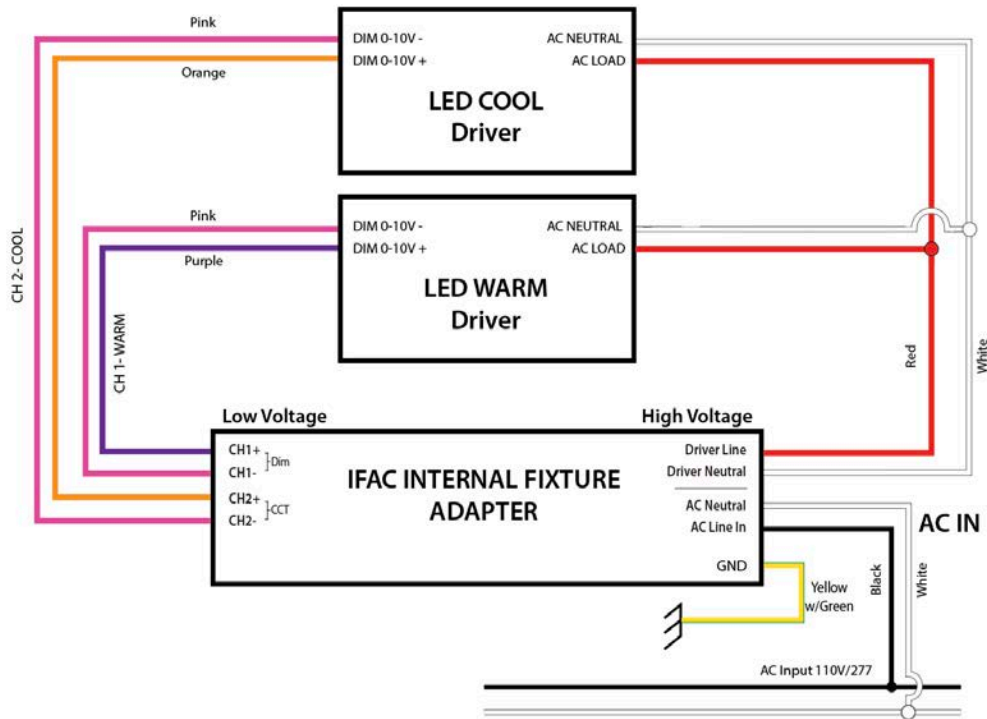

Figure 4. Wiring Diagram (2CH Warm/Cool)

ALL PRODUCT, PRODUCT SPECIFICATIONS AND DATA ARE SUBJECT TO CHANGE WITHOUT NOTICE TO IMPROVE RELIABILITY, FUNCTION OR DESIGN OR OTHERWISE. The information contained herein is believed to be reliable. Avi-on makes no warranty, representation or guarantee regarding the information contained herein, the suitability of the products for any particular purpose, or the continuing production of any product. Avi-on assumes no responsibility or liability whatsoever for the use of the information contained herein. The information contained herein, or any use of such information does not grant, explicitly or implicitly, to any party any patent rights, licenses, or any other intellectual property rights, whether with regard to such information itself or anything described by such information.

